

# Atmospheric pressure transmitter CP 116

## KEY POINTS

- Measuring range from 800 to 1100 hPa
- Indication of the pressure in mbar, mmHG ou hPa
- 0-10 V or 4-20 mA output, active, power supply 24 Vac/Vdc (3-4 wires) or 4-20 mA output, passive loop, power supply from 16 to 30 Vdc (2 wires)
- ABS V0 housing, IP65, with or without display
- "¼ turn" system mounting with wall-mount plate
- Housing with simplified mounting system



## FEATURES OF THE HOUSING

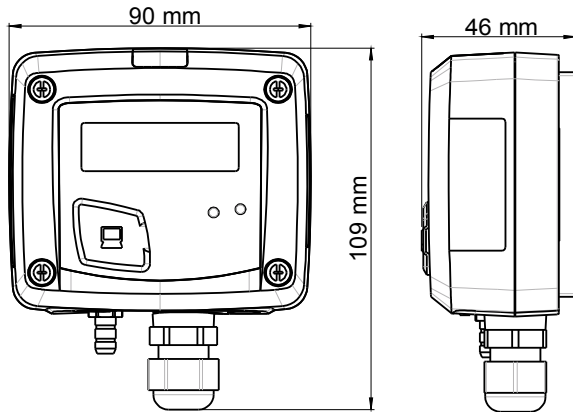

**Material** : ABS V0 as per UL94

**Protection** : IP65

**Display** : LCD 10 digits. Size : 50 x 17 mm

**Height of digits** : Value : 10 mm ; Unit : 5 mm

**Connections** : ribbed, Ø 6.2 mm

**Cable gland** : for cables Ø 8 mm maximum

**Weight** : 143 g

## TECHNICAL FEATURES

|                              |                         |
|------------------------------|-------------------------|
| <b>Measurement units</b>     | mbar, hPa, mmHG         |
| <b>Accuracy*</b>             | ±3 hPa                  |
| <b>Response time</b>         | < 10 seconds            |
| <b>Resolution</b>            | 1 mbar ; 1 hPa ; 1 mmHG |
| <b>Type of fluid</b>         | Air and neutral gases   |
| <b>Operating temperature</b> | From 0 to +50 °C        |
| <b>Storage temperature</b>   | From -10 to +70 °C      |

\*All the accuracies indicated in this technical datasheet were stated in laboratory conditions, and can be guaranteed for measurements carried out in the same conditions, or carried out with calibration compensation.

## PART NUMBER

To order, just add the codes to complete the part number :

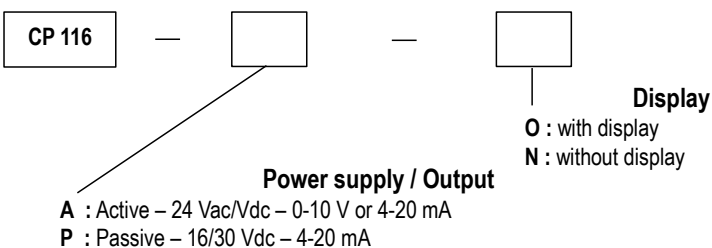

**Example : CP 116 – PO**

Transmitter of atmospheric pressure, passive transmitter 16/30 Vdc, with display

## TECHNICAL SPECIFICATIONS

|  |  |
|--|--|
| <b>Output / Power supply</b>           | - active sensor 0-10 V or 4-20 mA (alim. 24 Vac/Vdc $\pm$ 10%), 3-4 wires<br>- passive loop 4-20 mA (power supply 16/30 Vdc), 2 wires<br>- maximum load : 500 Ohms (4-20 mA)<br>- minimum load : 1 K Ohms (0-10 V) |
| <b>Consumption</b>                     | 2 VA (0-10 V) or max. 22 mA (4-20 mA)  |
| <b>Electromagnetical compatibility</b> | EN61326  |
| <b>Electrical connection</b>           | Screw terminal block for cables from 0.05 to 2.5 mm <sup>2</sup> or from 30 to 14 AWG  |
| <b>Communication PC</b>                | USB-mini DIN cable   |
| <b>Environment</b>                     | Air and neutral gases  |

## CONNECTIONS

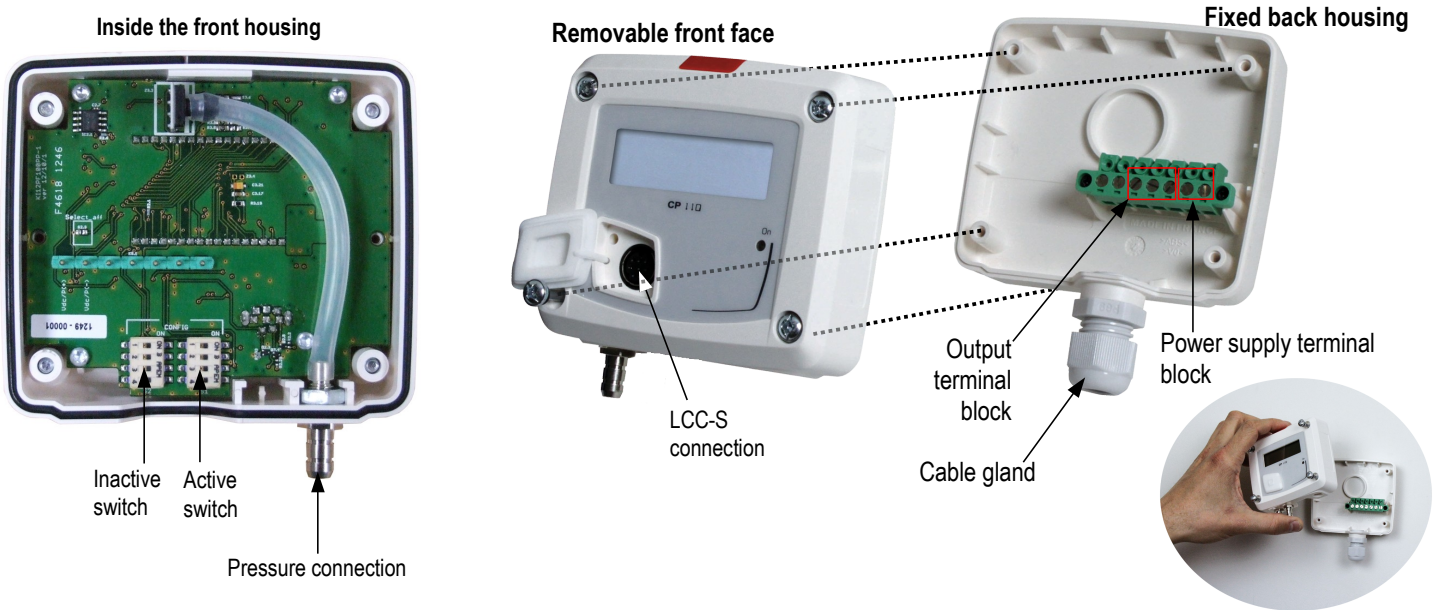

## ELECTRICAL CONNECTIONS – as per *NFC15-100* standard



This connection must be made by a qualified technician. **To make the connection, the transmitter must not be energized.**

For **CP116-AO** and **CP116-AN** models with 0-10 V or 4-20 mA output – active, **4 wires** :

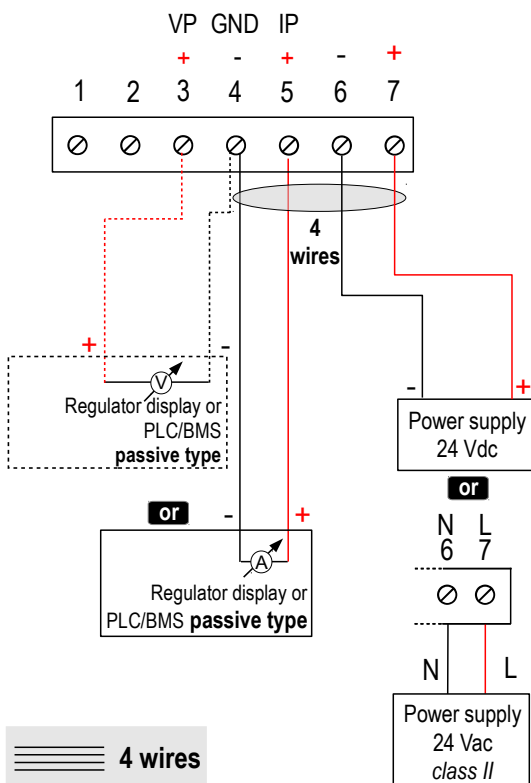

**To make a 3-wire connection, before powering up the transmitter, please connect the output ground to the input ground. See drawing below.**

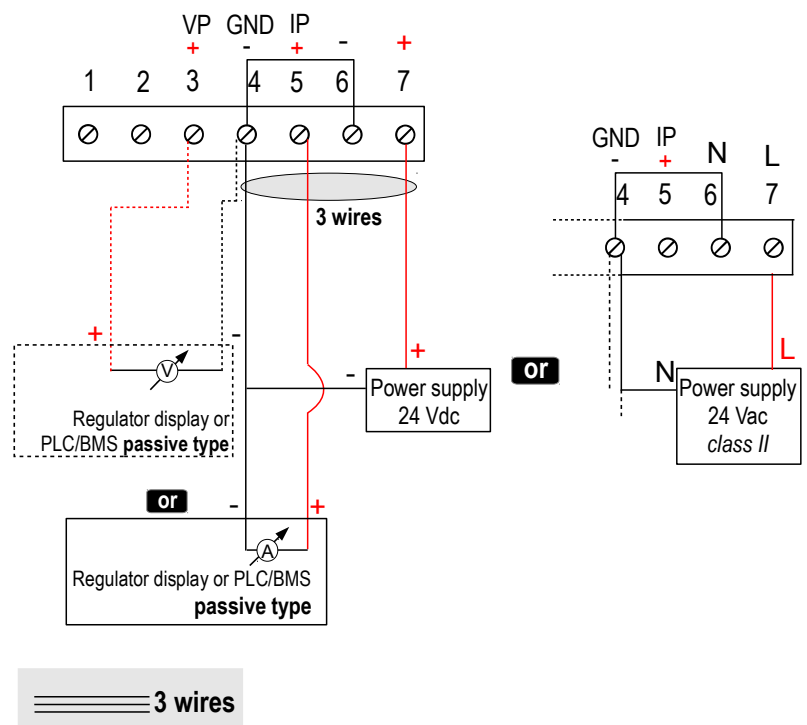

**4 wires**

**3 wires**

For CP116-PO and CP116-PN models with 4-20 mA output – passive :

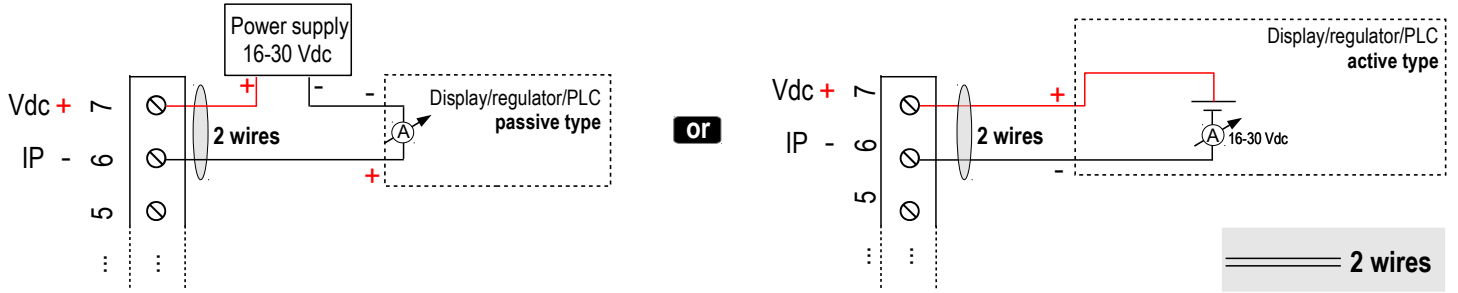

## SETTINGS AND USE OF THE TRANSMITTER

### > Configuration



To configure the transmitter, it must not be energized. Then, you can make the settings required, with the DIP switches (as shown on the drawing below). When the transmitter is configured, you can power it up.

To configure the transmitter, unscrew the 4 screws from the housing then open it. DIP switches allowing the different settings are then accessible.

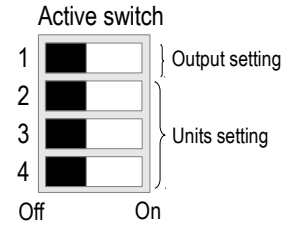

Please follow carefully the combinations beside with the DIP switch. If the combination is wrongly done, the following message will appear on the display of the transmitter "CONF ERROR". In that case, you will have to unplug the transmitter, place the DIP switches correctly, and then power the transmitter up.

### > Output setting – active switch

To set the type of analogue output, please put the on-off switch of the output as shown beside.

| Configurations | 4-20 mA   | 0-10 V  |
|----------------|---|---|
| Combinations   | 1 <input checked="" type="checkbox"/> <input type="checkbox"/><br>2 <input type="checkbox"/> <input type="checkbox"/><br>3 <input type="checkbox"/> <input type="checkbox"/><br>4 <input type="checkbox"/> <input type="checkbox"/> | 1 <input type="checkbox"/> <input checked="" type="checkbox"/><br>2 <input type="checkbox"/> <input type="checkbox"/><br>3 <input type="checkbox"/> <input type="checkbox"/><br>4 <input type="checkbox"/> <input type="checkbox"/> |

### > Units setting – active switch

To set a measurement unit, put the on-off switches 2, 3 and 4 of the units as shown in the table below.

| Configurations | mbar   | mmHG   | hPa  |
|----------------|--|--|--|
| Combinations   | 1 <input type="checkbox"/> <input type="checkbox"/> <input type="checkbox"/><br>2 <input type="checkbox"/> <input type="checkbox"/> <input type="checkbox"/><br>3 <input checked="" type="checkbox"/> <input type="checkbox"/> <input type="checkbox"/><br>4 <input checked="" type="checkbox"/> <input type="checkbox"/> <input type="checkbox"/> | 1 <input type="checkbox"/> <input type="checkbox"/> <input type="checkbox"/><br>2 <input type="checkbox"/> <input type="checkbox"/> <input type="checkbox"/><br>3 <input type="checkbox"/> <input checked="" type="checkbox"/> <input type="checkbox"/><br>4 <input checked="" type="checkbox"/> <input type="checkbox"/> <input type="checkbox"/> | 1 <input type="checkbox"/> <input type="checkbox"/> <input type="checkbox"/><br>2 <input type="checkbox"/> <input type="checkbox"/> <input type="checkbox"/><br>3 <input checked="" type="checkbox"/> <input checked="" type="checkbox"/> <input type="checkbox"/><br>4 <input type="checkbox"/> <input checked="" type="checkbox"/> <input checked="" type="checkbox"/> |

## CONFIGURATION VIA LCC-S SOFTWARE (option)

An easy and friendly configuration with the software !

- To access the configuration via software :
  - Set the DIP switches as shown beside. *Nota : the on-off switch 1 of the active DIP switch can be in any position (selection of the analogue output 0-10 V or 4-20 mA).*
  - Connect the cable of the LCC-S to the connection of the transmitter.
- Please refer to the user manual of the LCC 100 to make the configuration.

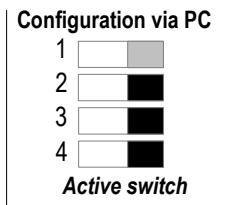

The configuration of the parameters can be done either with the DIP switch or via software (you can not combine both solutions).

## MOUNTING

To mount the transmitter, mount the ABS plate on the wall (drilling :  $\varnothing 6$  mm, screws and pins are supplied).

Insert the transmitter on the fixing plate (see A on the drawing beside). Rotate the housing in clockwise direction until you hear a "click" which confirms that the transmitter is correctly installed.

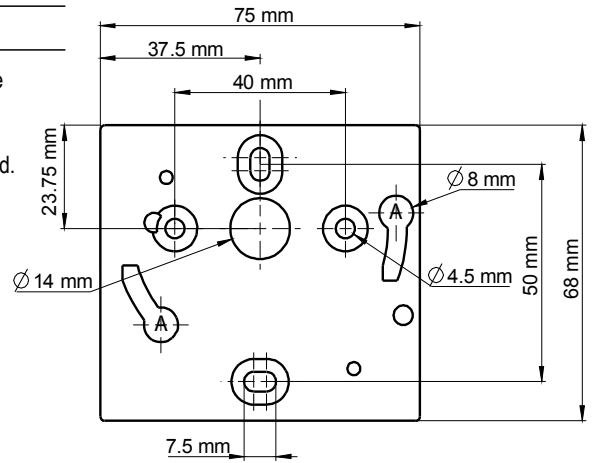

## MAINTENANCE

Please avoid any aggressive solvent. Please protect the transmitter and its probes from any cleaning product containing formalin, that may be used for cleaning rooms or ducts.

## OPTIONS AND ACCESSORIES

- **KIAL-100A** : Power supply class 2, 230 Vac input, 24 Vac output
- **KIAL-100C** : Power supply class 2, 230 Vac input, 24 Vdc output
- **LCC-S** : configuration software with USB cable
- Connection tube
- Connection fittings
- Through-connections
- Straight connections
- Spherical coupling nut

[www.kimo.fr](http://www.kimo.fr)



EXPORT DEPARTMENT

Tel : + 33. 1. 60. 06. 69. 25 - Fax : + 33. 1. 60. 06. 69. 29

e-mail : [export@kimo.fr](mailto:export@kimo.fr)

Distributed by :



**TR instruments**

Tel.: +420 541 633 670

Fax: +420 541 212 413

Křižíkova 70, 612 00 Brno

[tri@trinstruments.cz](mailto:tri@trinstruments.cz)